

Technical Product Information

Pump Mixing Unit

Article no. 12532



III. 1

Scope of application

In low-temperature radiant panel heating systems, the pump mixing unit is used to keep the supply temperature constant. The supply temperature is continuously adjustable between 20 °C and 70 °C on the selector dial of the thermostat head. You can limit the setting range with a minimum and a maximum temperature. The thermometer of the pump mixing unit indicates the supply temperature.

The pump mixing unit is suitable for heating systems that emit heat via consumers requiring high supply temperatures (such as radiators, air heaters and similar equipment) as well as for low-temperature radiant panel heating systems (such as underfloor heating or radiating wall heating).

The pump mixing unit is designed for direct assembly to the heating manifold. One-inch male thread connections are provided for this purpose. The pump mixing unit is fitted with one-inch spigot nuts. Adapters for the connection to manifolds with profiled pipes are enclosed in the delivery.

The pump mixing unit is suitable for dry rooms in residential and industrial buildings. It is typically installed in a boiler room or in a distribution cabinet.

Make sure that you use the device for the intended purpose before putting it into operation.

Notes, symbols, short-cuts

MT	male thread	BP	backflow preventer
WH	wall heating	FF&D	flush, fill and drain unit
RPH	radiant panel heating (general)	GFS	gravity flow stop
CG-RPH	control group for radiant panel heating	TL	temperature limiter
HCCU	heating circuit control unit	SN	spigot nut
HCCUwM	heating circuit control unit with mixer	CP	Circulation pump
HM	heating manifold	TIS	thermal insulation sleeve
FT	female thread	HG	heat generator
A&OM	assembly and operating manual		
→	Reference to further information		
i	Important information and application tips		
	Danger warning notice or important functional notice		

Safety notice

 Disconnect the system from the power supply prior to the commencement of work! Make sure that you perform any assembly and wiring work on the pump mixing unit only in idle state. Only skilled personnel shall connect or commission the unit. Applicable safety regulations, especially VDE 0100 shall be adhered to. The pump mixing unit is not protected against splashing or dripping water. Therefore, make sure that you install it in a dry place.

- 1: Supply flow of panel heating (1" SN)
- 2: Return flow of panel heating (1" SN)
- 3: Supply flow of boiler/radiator circuit (1" MT)
- 4: Return flow of boiler/radiator circuit (1" MT)
- with backflow preventer (BP)
- 5: Circulation pump
- 6: Thermostat head
- 7: Injection/mixing valve
- 8: Backflow preventer (BP)
- 9: Supply flow thermometer
- 10: Temperature limiter (optional)
- 11: Eccentric screw connection with submersible sleeve for supply temperature sensor

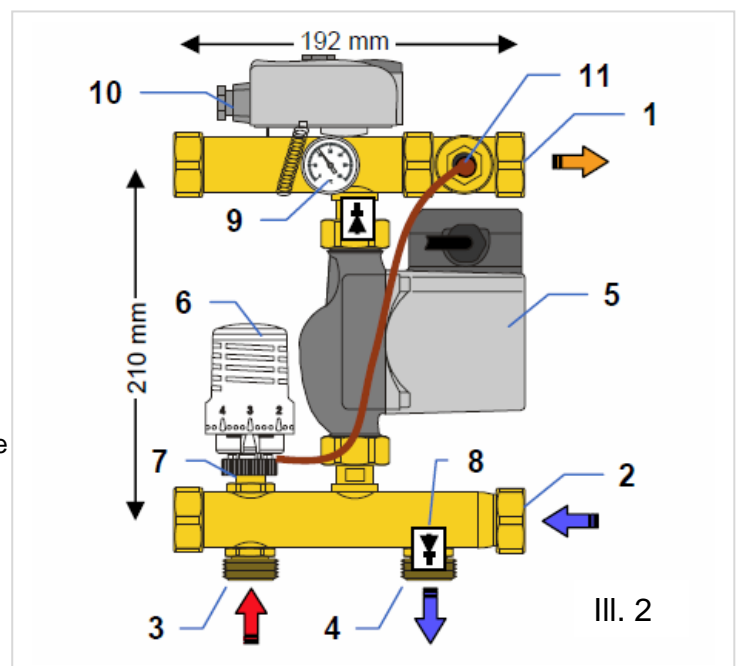

Assembly The pump mixing unit is designed for direct fitting to the WEM heating manifold to the one-inch male thread connectors with flat gaskets. When fitting the unit, take care not to kink or damage the cables of the pump and the temperature limiter or the capillary sensor tube.

No tensile stress should act on the cables. Make sure that you connect the supply and return flows correctly (III. 2).

Electrical connection In general, the pump and the optional temperature limiter are wired in the factory. The power supply must be provided by the customer. To ensure that the pump only runs when heating is required, we recommend connecting it to a pump relay (e. g. WEM Master Wiring Module, article no. 12612). All electrical connecting work shall be performed by an authorised electrician in accordance with locally applicable regulations on electrical installations. The electrical cables must not come into contact with hot parts.

Commissioning

Flushing the heating circuits Connect the pump mixing unit to the pipe network and isolate it (by means of the ball valves included in the scope of the heating manifold (HM) or by any shut-off device made available on site). Switch off the pump and shut off all heating circuits on the manifold (it is sufficient to close the valves in the return flow manifold with the protection caps). Connect the flush and drain pipe to the flush, fill and drain unit (FF&D) fitted to the manifold. Open the desired heating circuit and start flushing in the flow direction until the air and any contamination has been drained from the heating circuit. The backflow preventer upstream of the pump prevents any bypasses that might affect the orderly flushing and filling process of the heating circuits.

IMPORTANT NOTICE: Always observe the flow direction, i. e. make sure that the water flows into the circuit at the supply bar and flows out of it at the return bar! The drain must always be open to prevent excessive water pressure that might damage the heating system. The instructions concerning flushing in the operating manual of the heating manifold shall also be observed.

Adjusting the supply temperature

At maximum power demand (rated output), the boiler supply temperature must exceed the desired supply temperature in the wall heating circuit by at least 15 °C! The supply temperature is continuously adjustable between 20 °C and 70 °C. The dial of the thermostat head offers 7 positions. (III. 3; A). The associated temperature is given in the table below:

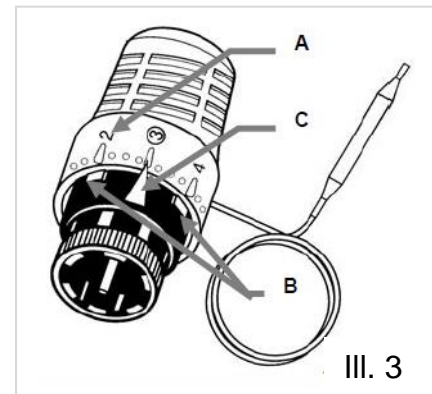

1	2	3	4	5	6	7
20°C	28 °C	37 °C	45 °C	53 °C	62 °C	70 °C

Limiting the supply temperature

Under normal conditions, the max. supply temperature for a radiant panel heating is 50 °C. The system temperature is often considerably lower than the max. value on the dial of the thermostat head. To avoid overtemperature, you can limit the desired range of supply temperatures on the thermostat head and lock the settings. To do this, first adjust the desired value and check it during the operation of the panel heating on the thermometer. If the adjusted value is appropriate, apply the locking devices (III. 3; B) to the desired limit values on both sides of the marking arrow (III. 3; C).

Functioning of the pump mixing unit

The injection valve is conceived as a proportional controller and requires no auxiliary energy supply. The remote sensor of the thermostat head is fitted in the supply flow and measures continuously the actual supply temperature. Deviations from the desired value trigger immediately a change of the valve stroke to adjust the amount of injected hot water from the boiler circuit. The injected water mixes with the return water from the manifold at the inlet of the circulation pump and keeps the supply temperature constant in a narrow temperature range.

Technical
data/
materials

Permissible ambient temperature:	0 to 40 °C ¹⁾
Permissible medium temperature:	0 to 80 °C ¹⁾
Max operating pressure:	6 bars
Control range of supply temperature:	20 to 70 °C
Thermal rating:	approx. 14 kW ²⁾
Operating voltage:	230 V, 50 Hz
Valves and fittings:	brass Ms 58
Pipe sections:	brass Ms 63 or stainless steel
Plastic materials:	impact-resistant and temperature fast
Flat gaskets:	AFM 34 or EPDM
O-rings:	EPDM

¹⁾ The specifications in the pump description and the pump operating instructions shall be observed in addition.

²⁾ To achieve the thermal rating, the pressure difference between the primary circuit (heat generator/radiator circuit) and the secondary circuit (radiant panel heating) should be 150 mbar minimum. The temperature difference between the primary supply flow and the secondary supply flow should be 15 K minimum.

Trouble
shooting

	<u>Possible cause</u>	<u>Remedy</u>
1	<u>WALL HEATING CIRCUITS DO NOT HEAT UP</u>	
1.1	The temperature limiter (TL) switches off the circulation pump of the pump mixing unit. Cause: The value set on the TL is too low.	Increase the wall heating supply temperature on the TL by approx. 10 K. ⚠ Make sure to observe the permissible maximum temperature! ⚠ The differential gap of the TL is 6 K approx.

	Possible cause	Remedy
1.2	<p>The TL switches off the circulation pump of the pump mixing unit. Cause: The circulation pump remains active for a while even after all WH circuits have been shut off. The water circulating via the bypass in idle run is heated up by the emitted heat of the circulation pump. The TL switches the circulation pump off when the maximum temperature is reached!</p>	<p>Disassemble the TL from the compact pump mixing unit and fit it to the supply flow or even to the return flow on the heating manifold. Use a wiring centre with pump control logic (e. g. WEM Master Wiring Module). The pump control logic ensures that the circulation pump runs only when at least one heating circuit is open.</p>
1.3	<p>The circulation pump is connected to a room thermostat or a wiring centre. When all actuators close, the pump is switched off. During longer periods of inactivity, the supply flow of the WH cools down. The injection mixing valve opens again, and hot water is injected into the primary circuit. This heats up the pump mixing unit. When the temperature reaches the switch-off level set on the TL the contact opens. The pump is not switched on again.</p>	<p>Disassemble the TL from the compact pump mixing unit and fit it to the supply flow or even to the return flow on the heating manifold. <i>Consider also item 1.1.</i></p>
1.4	<p>The difference of the boiler supply temperature and the desired wall heating supply temperature is insufficient for the existing heat load.</p>	<p>Set a higher boiler supply temperature on the boiler. To deliver the maximum thermal output of the wall heating, the supply temperature of the boiler must exceed the desired wall heating supply temperature by 15 °C minimum!</p>

	Possible cause	Remedy
2	<u>WH SUPPLY TEMPERATURE CANNOT BE ADJUSTED TO THE DESIRED VAUE OR THE SUPPLY TEMPERATURE VARIES SEVERELY.</u>	
2.1	The supply and return flows are connected reversely to the compact pump mixing unit.	Check all connections of the compact pump mixing unit. The connections are identified by adhesive labels. Refer to Ill. 2.
2.2	The pump head/pump stage is adjusted to an insufficient level.	Increase the speed and/or the head of delivery of the pump.
2.3	The heating load is too high for the connected compact pump mixing unit, i. e. the heat consumption exceeds the thermal rating of the compact pump mixing unit. This state might occur temporarily when heating up a cold floor for instance.	Assess the maximum heat demand and compare it to the thermal rating. You probably need to distribute the heating circuits over two compact pump mixing units in combination with a suitable HM. If the problem occurs when the WH is operated for the first time, it is still possible, that the system returns to trouble-free operation after the heating-up phase. This may be the case when the heating is operated at the upper thermal rating.
2.4	The thermostat head is defective.	Replace the thermostat head.

⚠ Notice

Read this assembly and operating manual completely before commencing any assembly or commissioning work. Make sure to understand and observe the instructions when performing this work. Only trained specialist personnel may install, adjust and repair the pump mixing unit of the manifold. For any work on the product carried out by trainees ensure supervision by experienced personnel. The manufacturer will only assume liability in accordance with legal regulations if compliance with the above-mentioned stipulations is ensured.

All instructions of this assembly and operating manual (A&OM) shall be observed when operating the pump mixing unit. Any other use is inappropriate. The manufacturer excludes any claims of warranty for damages on the pump mixing unit resulting from inappropriate use. Modifications are not permissible for reasons of safety. Repair work on the pump mixing unit may only be carried out by a repair shop recommended by the manufacturer.